

www.dynergysrl.it

**Dynergy**

Energie alternative rinnovabili.  
Tecnologie per il risparmio energetico.

www.dynergysrl.it  
dynergy@dynergysrl.it



# D-DRY REC VE

Deumidificatori verticali con recuperatore ad altissima efficienza



# D-DRY REC

Deumidificatori orizzontali con recuperatore ad altissima

**ALLEGATO DISEGNI**



SOMMARIO

<b>1</b>	<b>DISEGNI DIMENSIONALI.....</b>	<b>4</b>
1.1	D-DRY REC 015.....	4
1.2	D-DRY REC 020.....	5
1.3	D-DRY REC 035.....	7
1.4	D-DRY REC 050.....	9
1.5	D-DRY REC 100.....	11
1.6	D-DRY REC-VE 020.....	14
1.7	D-DRY REC-VE 035.....	16
1.8	D-DRY REC-VE 050.....	18

# 1 DISEGNI DIMENSIONALI

## 1.1 D-DRY REC 015

### 1.1.1 Dimensionale D-DRY REC 015 (tutte le versioni)

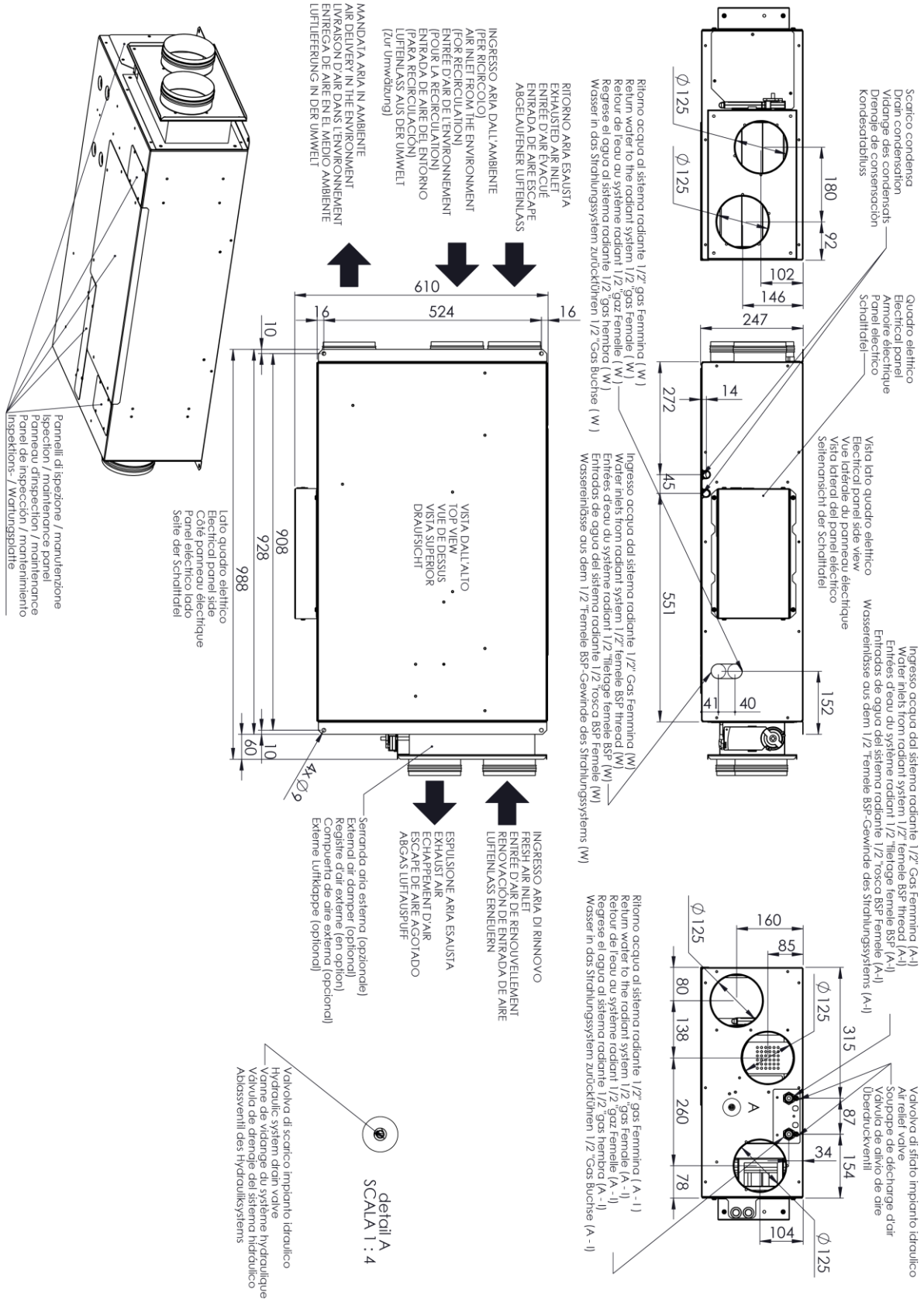

# 1.2 D-DRY REC 020

## 1.2.1 Dimensionale D-DRY REC 020 (tutte le versioni)

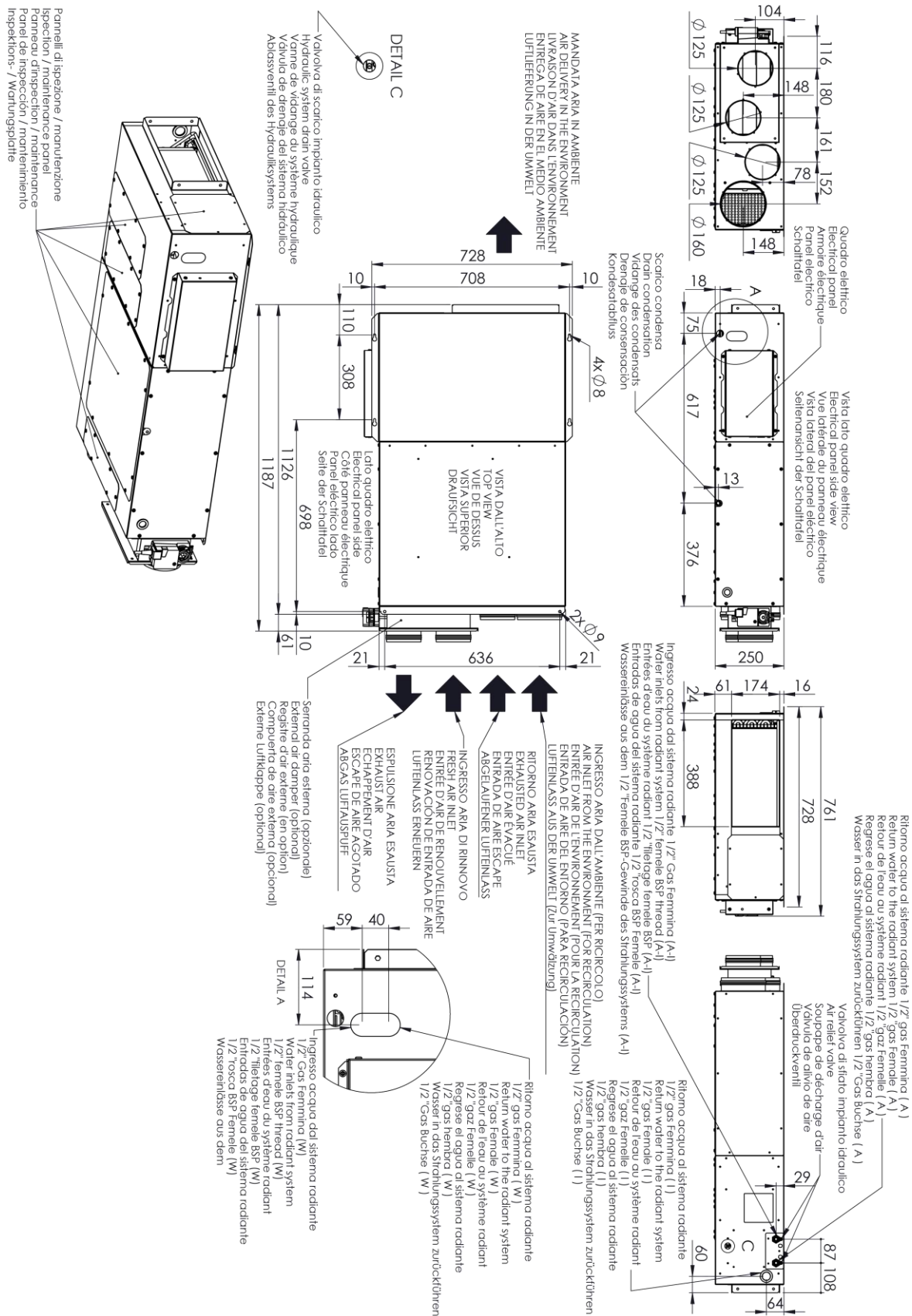

1.2.2 Plenum di mandata D-DRY REC 020

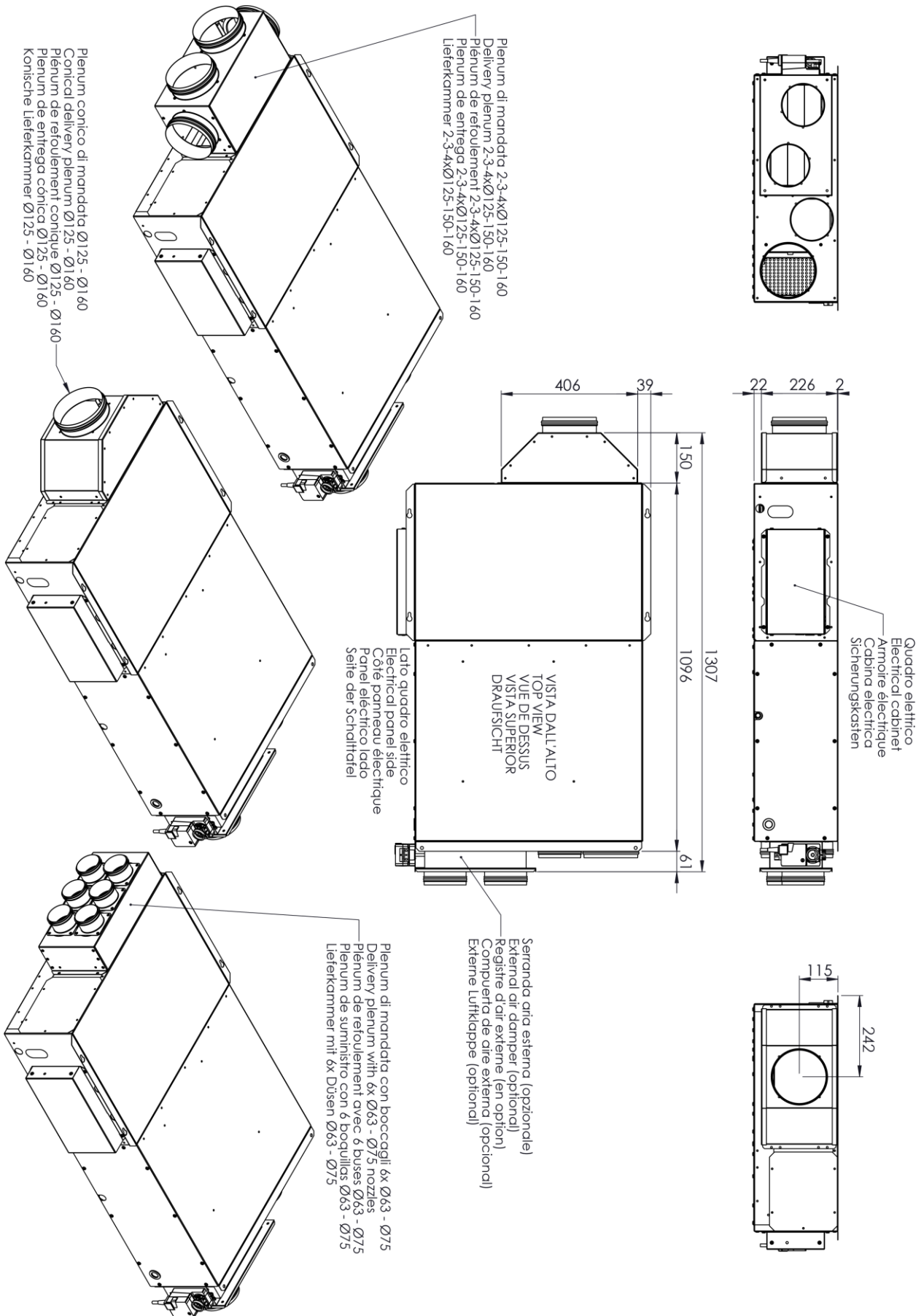

## 1.3 D-DRY REC 035

### 1.3.1 Dimensionale D-DRY REC 035 (tutte le versioni)

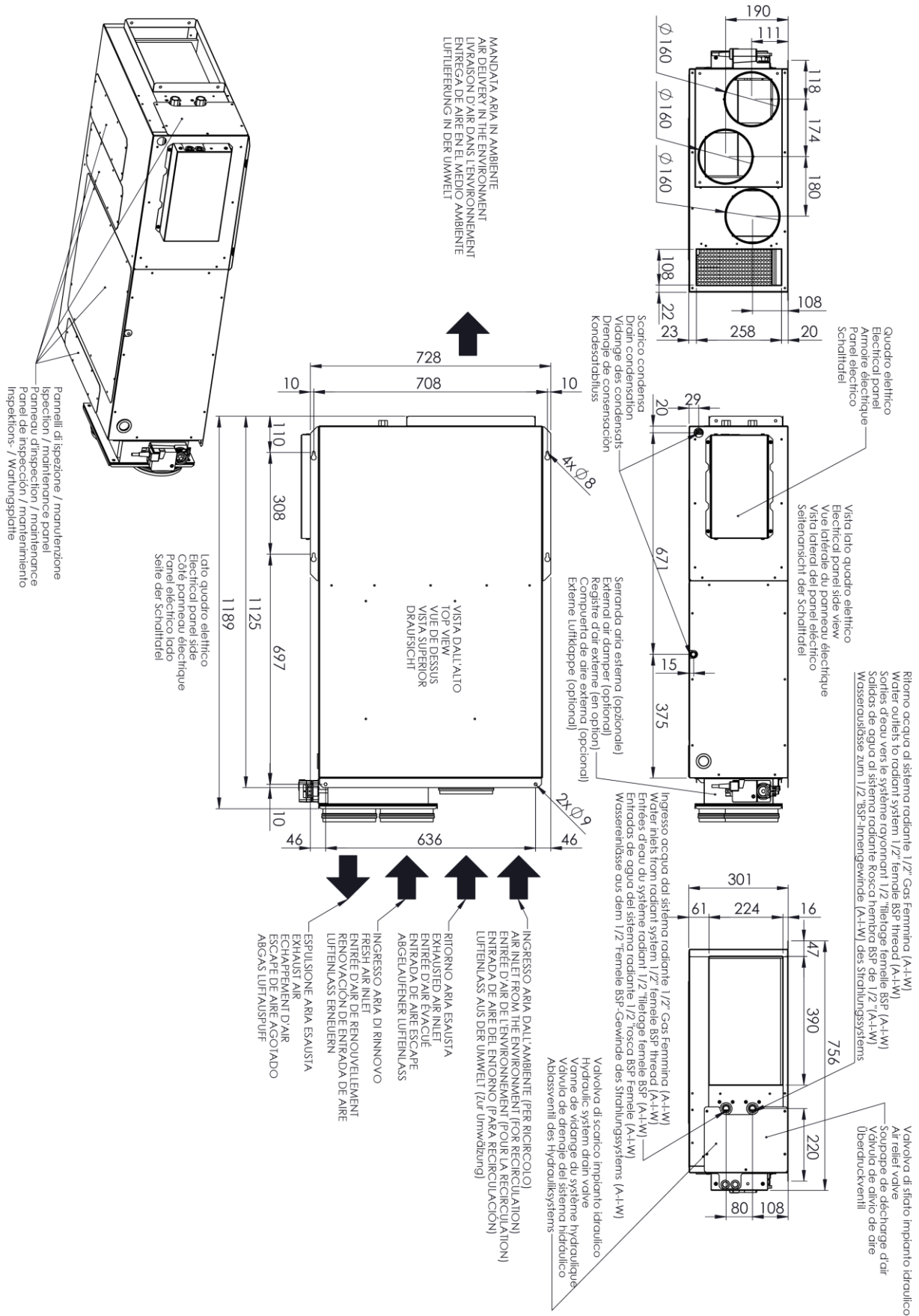

1.3.2 Plenum di mandata e di ricircolo D-DRY REC 035

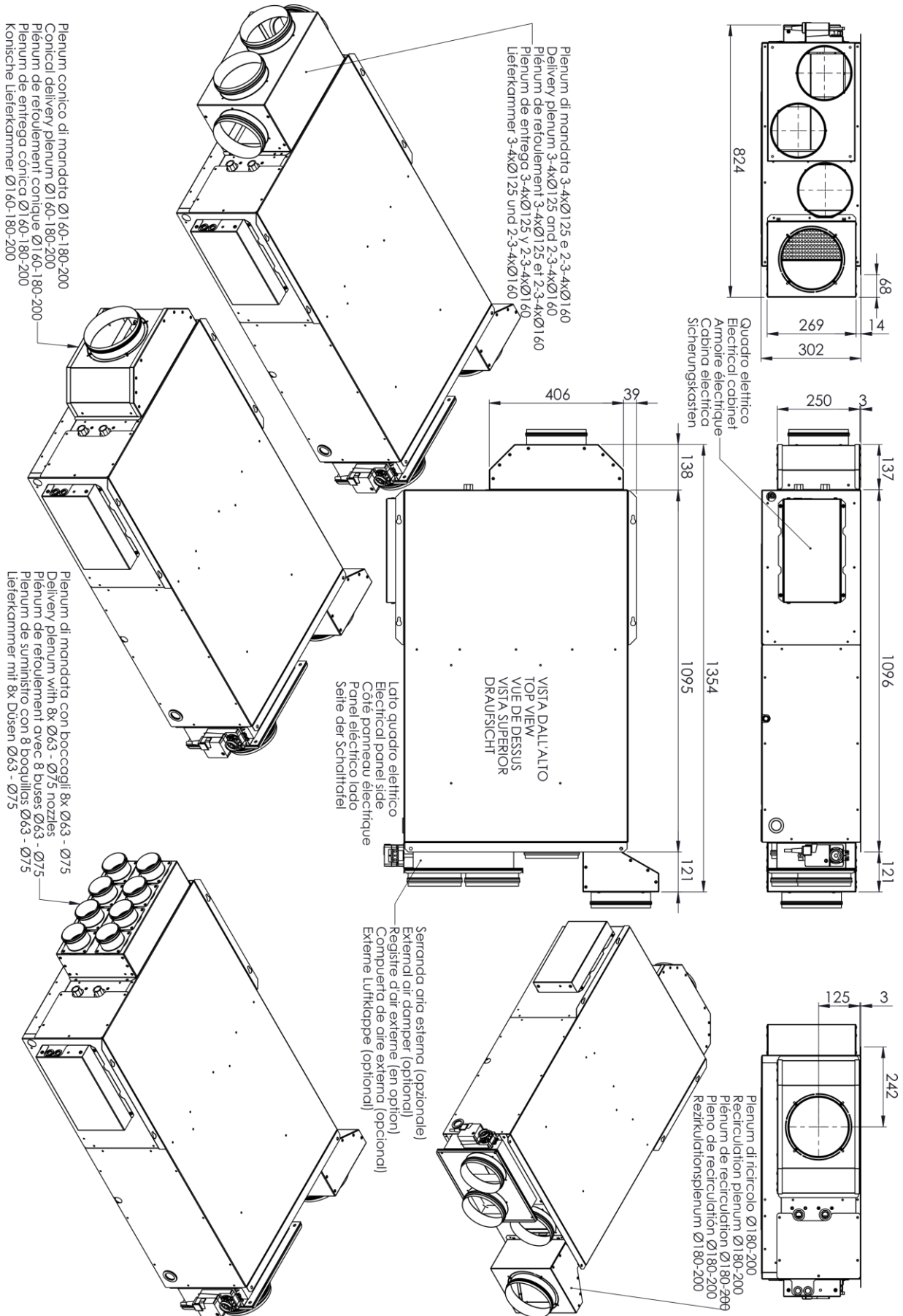



## 1.4 D-DRY REC 050

### 1.4.1 Dimensionale D-DRY REC 050 (tutte le versioni)

Pannelli di ispezione / manutenzione  
 Inspection / maintenance panel  
 Panneau d'inspection / maintenance  
 Panel de inspección / mantenimiento  
 Inspektions- / Wartungsplatte

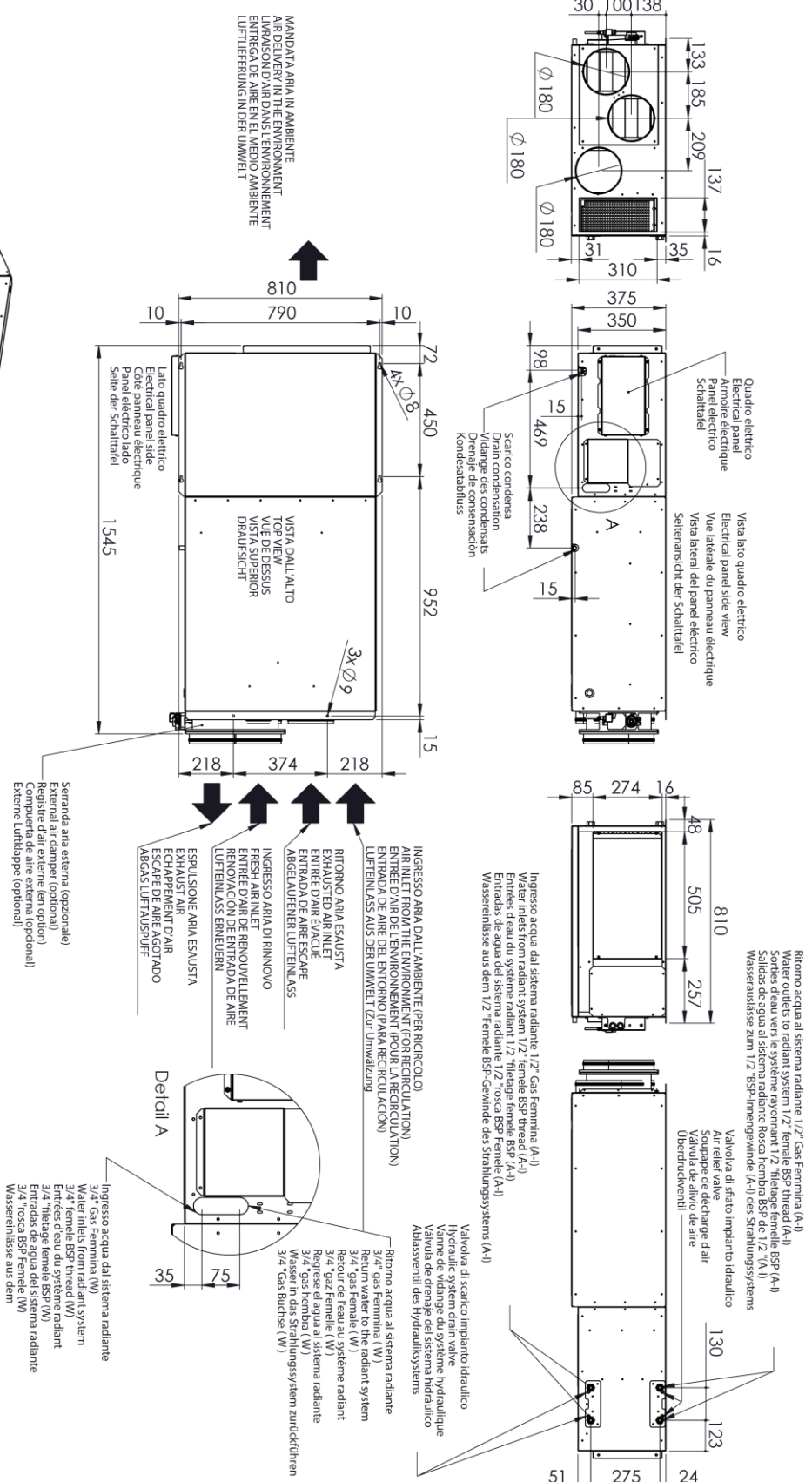
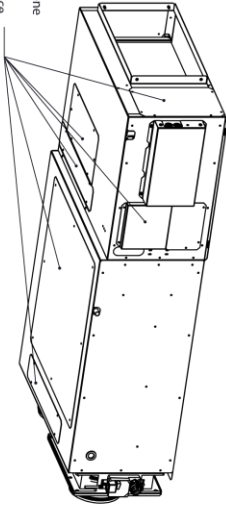

1.4.2 Plenum di mandata e di ricircolo D-DRY REC 050

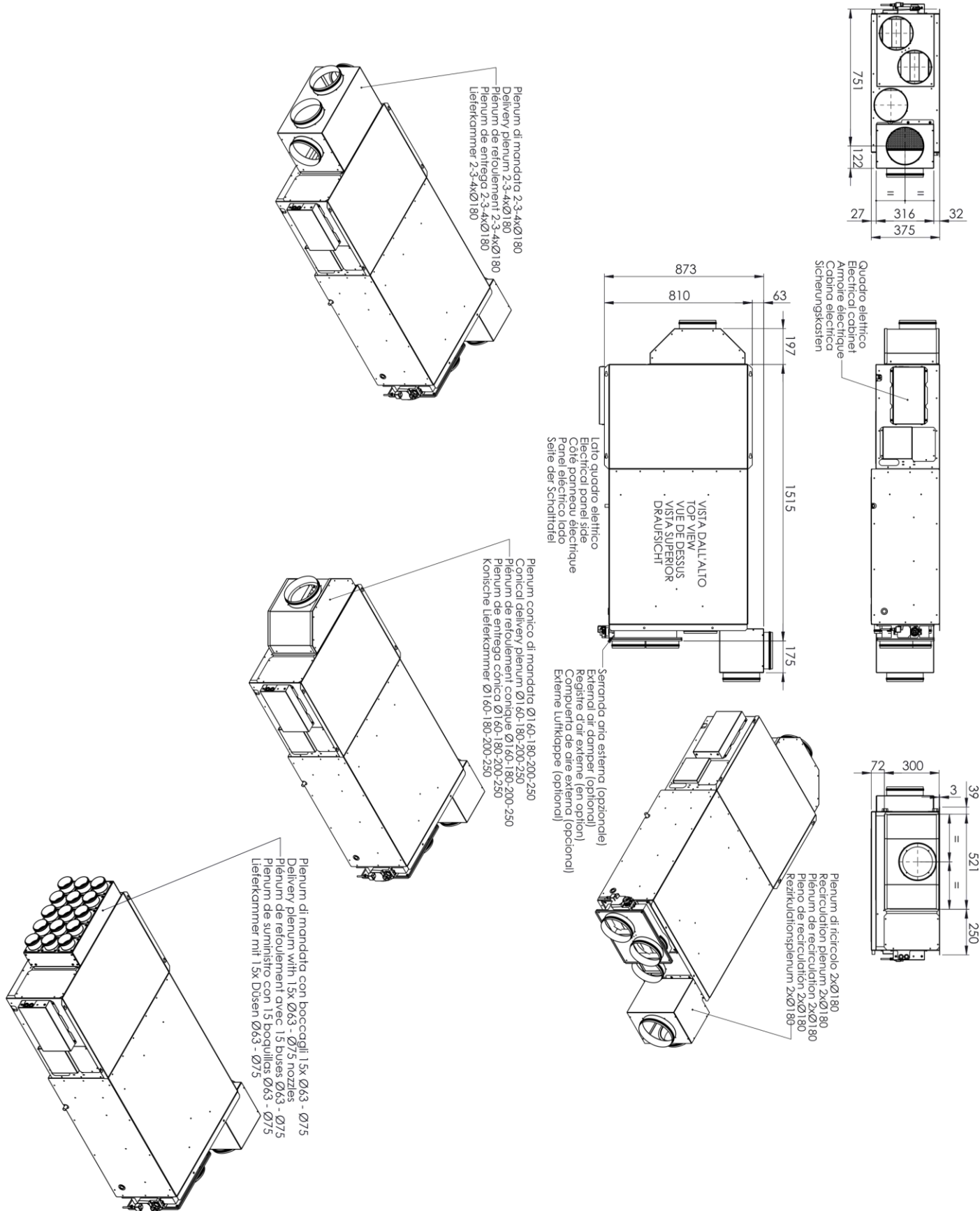

# 1.5 D-DRY REC 100

## 1.5.1 Dimensionale D-DRY REC 100 (tutte le versioni)

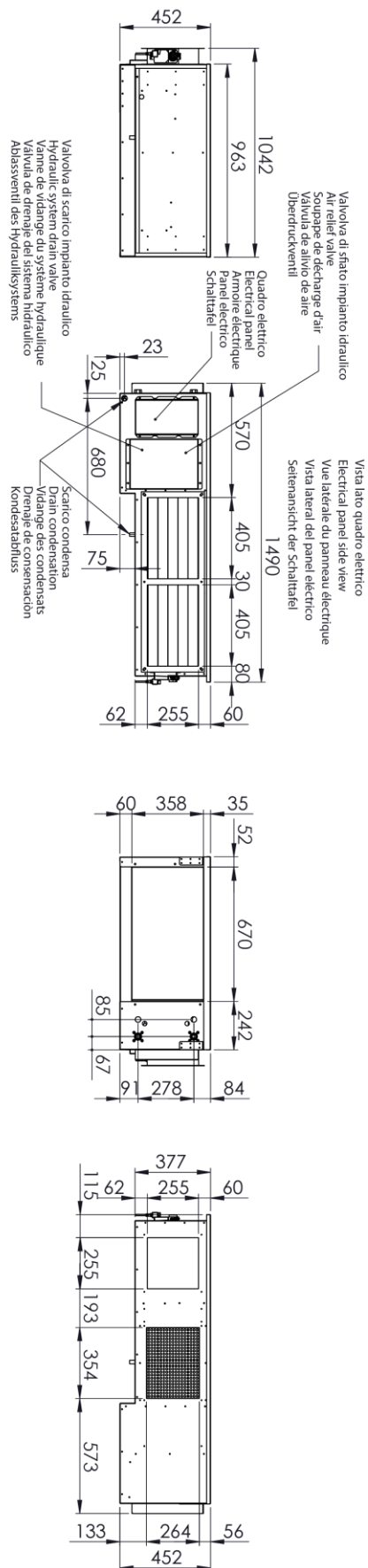
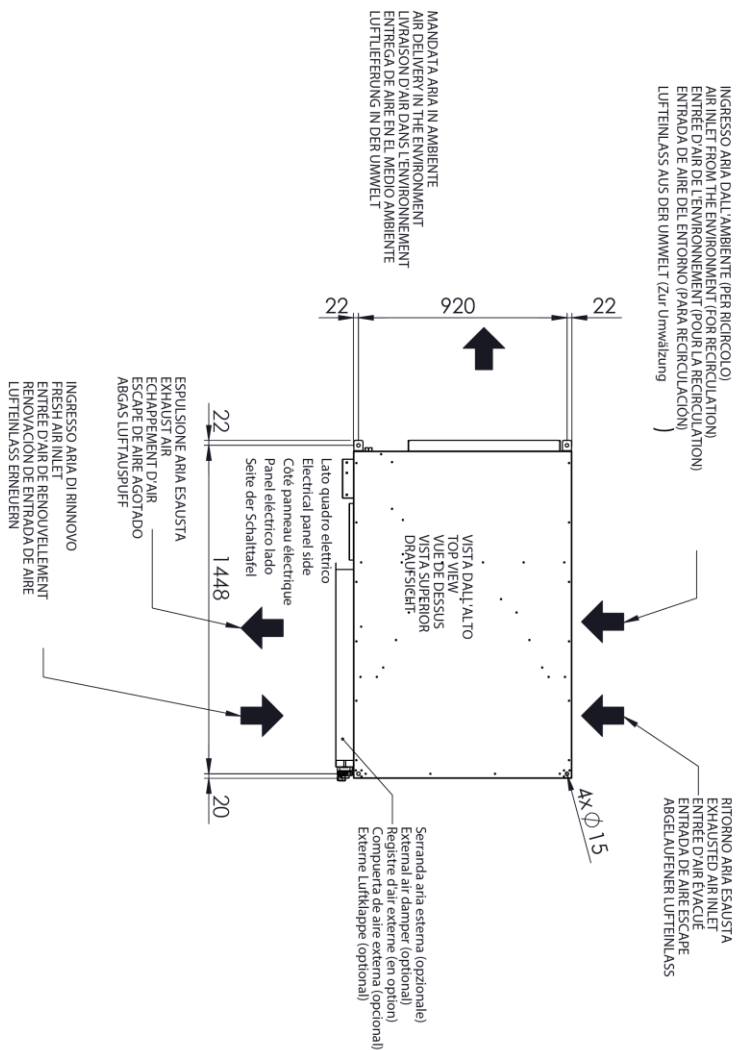

Ritorno acqua al sistema radiante 1/2" Gas Femmina (I)  
 Water outlets to radiant system 1/2" Female BSP thread (I)  
 Sortes d'eau vers le système rayonnant 1/2" filetage femelle BSP (I)  
 Salidas de agua al sistema radiante Rosca hembra BSP de 1/2" (I)  
 Wasserablassse zum 1/2" BSP-femengewinde (I) des Strahlungssystems

Ingresso acqua del sistema radiante 1/2" Gas Femmina (I)  
 Water inlets from radiant system 1/2" Female BSP thread (I)  
 Entrées d'eau du système rayonnant 1/2" filetage femelle BSP (I)  
 Entradas de agua del sistema radiante 1/2" rosca BSP Femelle (I)  
 Wasserreinlassse aus dem 1/2" Femelle BSP-Gewinde des Strahlungssystems (I)

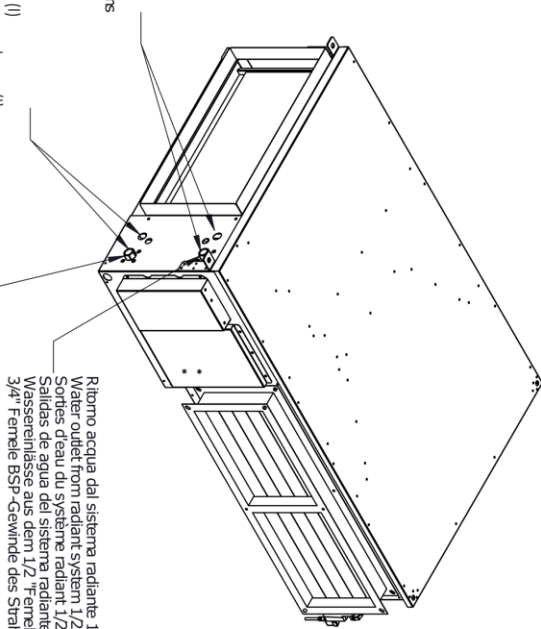

Ritorno acqua dal sistema radiante 1/2" Gas Femmina (A) - 3/4" Gas Femmina (W)  
 Water outlet from radiant system 1/2" Female BSP thread (A) - 3/4" Female BSP thread (W)  
 Sortes d'eau du système radiant 1/2" filetage femelle BSP (A) - 3/4" filetage femelle BSP (W)  
 Salidas de agua del sistema radiante 1/2" rosca BSP Femelle (A) - 3/4" rosca BSP Femelle (W)  
 Wasserreinlassse aus dem 1/2" Femelle BSP-Gewinde des Strahlungssystems (A) - 3/4" Femelle BSP-Gewinde des Strahlungssystems (W)

Ingresso acqua dal sistema radiante 1/2" Gas Femmina (A) - 3/4" Gas Femmina (W)  
 Water inlets from radiant system 1/2" Female BSP thread (A) - 3/4" Female BSP thread (W)  
 Entrées d'eau du système radiant 1/2" filetage femelle BSP (A) - 3/4" filetage femelle BSP (W)  
 Entradas de agua del sistema radiante 1/2" rosca BSP Femelle (A) - 3/4" rosca BSP Femelle (W)  
 Wasserreinlassse aus dem 1/2" Femelle BSP-Gewinde des Strahlungssystems (A) - 3/4" Femelle BSP-Gewinde des Strahlungssystems (W)

Pannelli di ispezione / manutenzione  
 Inspection / maintenance panel  
 Panneau d'inspection / maintenance  
 Panel de inspection / mantenimiento  
 Inspektions- / Wartungsplatte

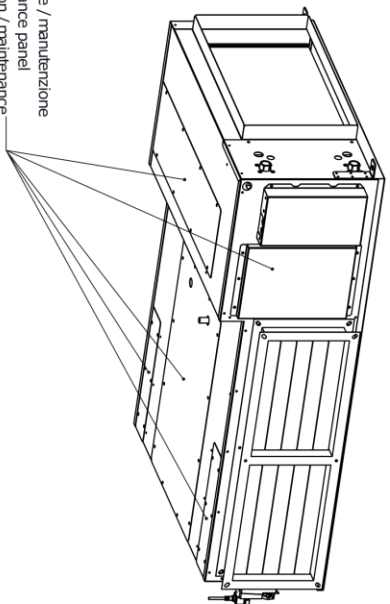

1.5.2 Plenum di mandata e di ricircolo D-DRY REC 100

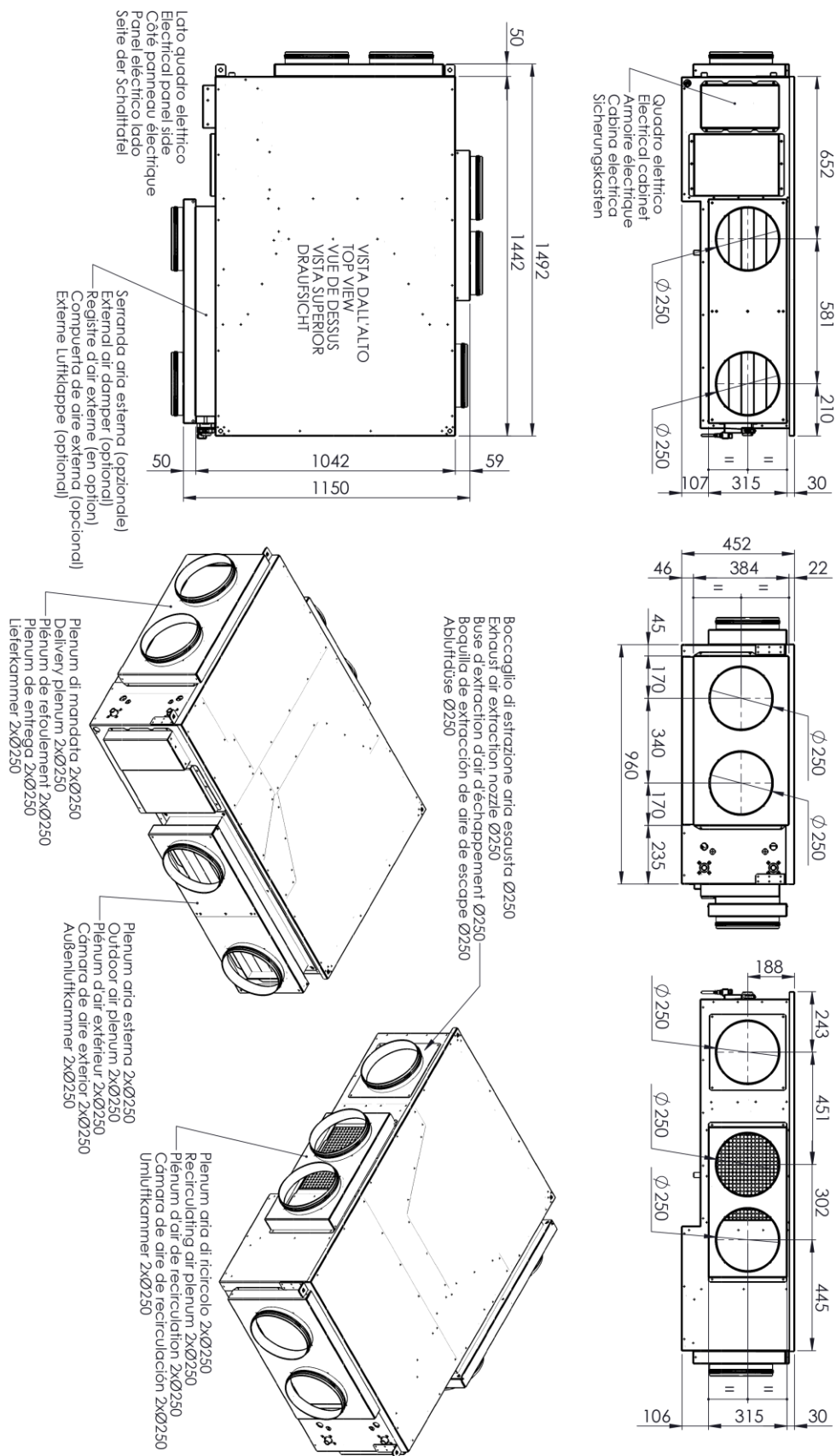

## 1.6 D-DRY REC-VE 020

### 1.6.1 Dimensionale D-DRY REC-VE 020 (tutte le versioni)

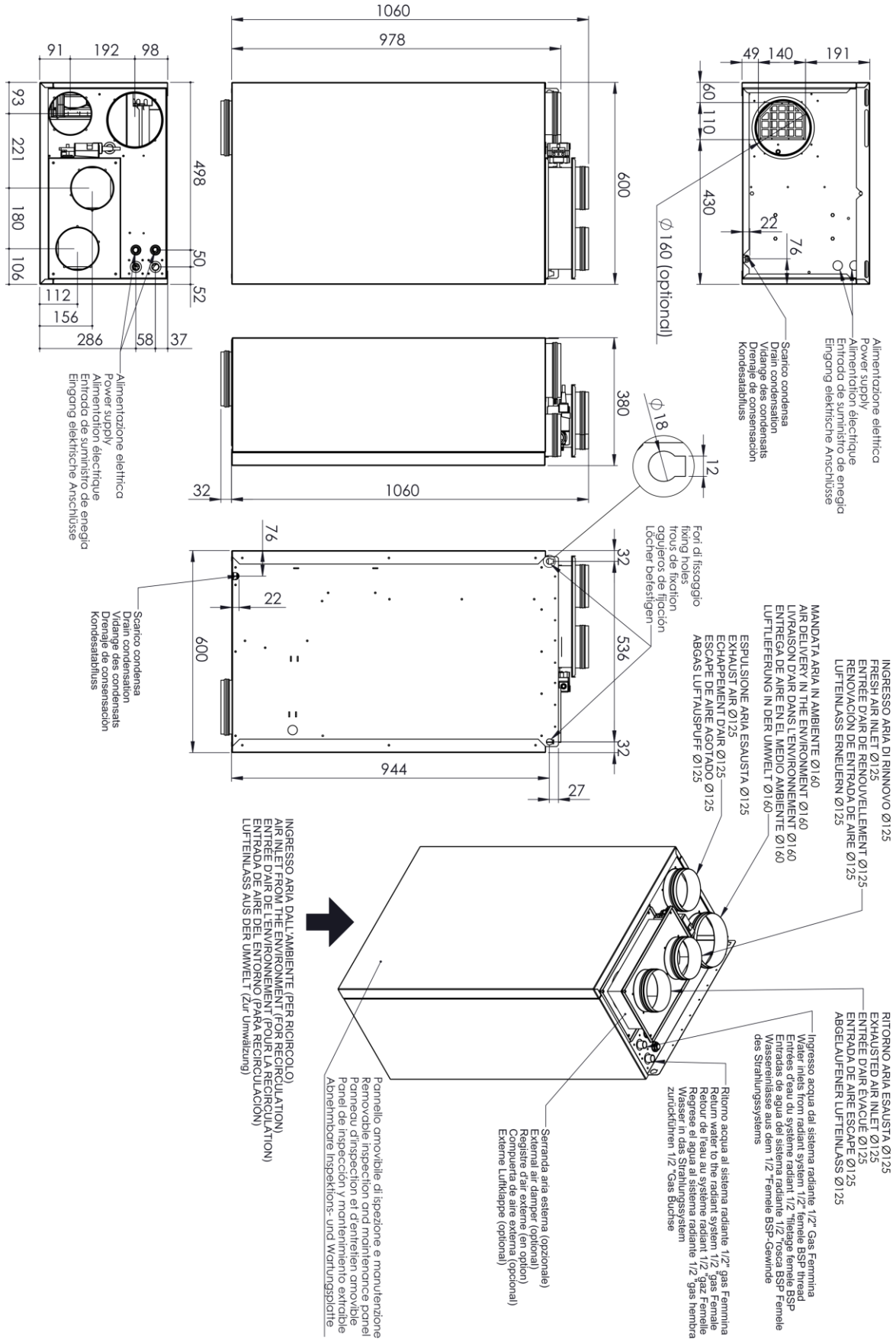

1.6.2 Dimensionale plenum ricircolo D-DRY REC-VE 020

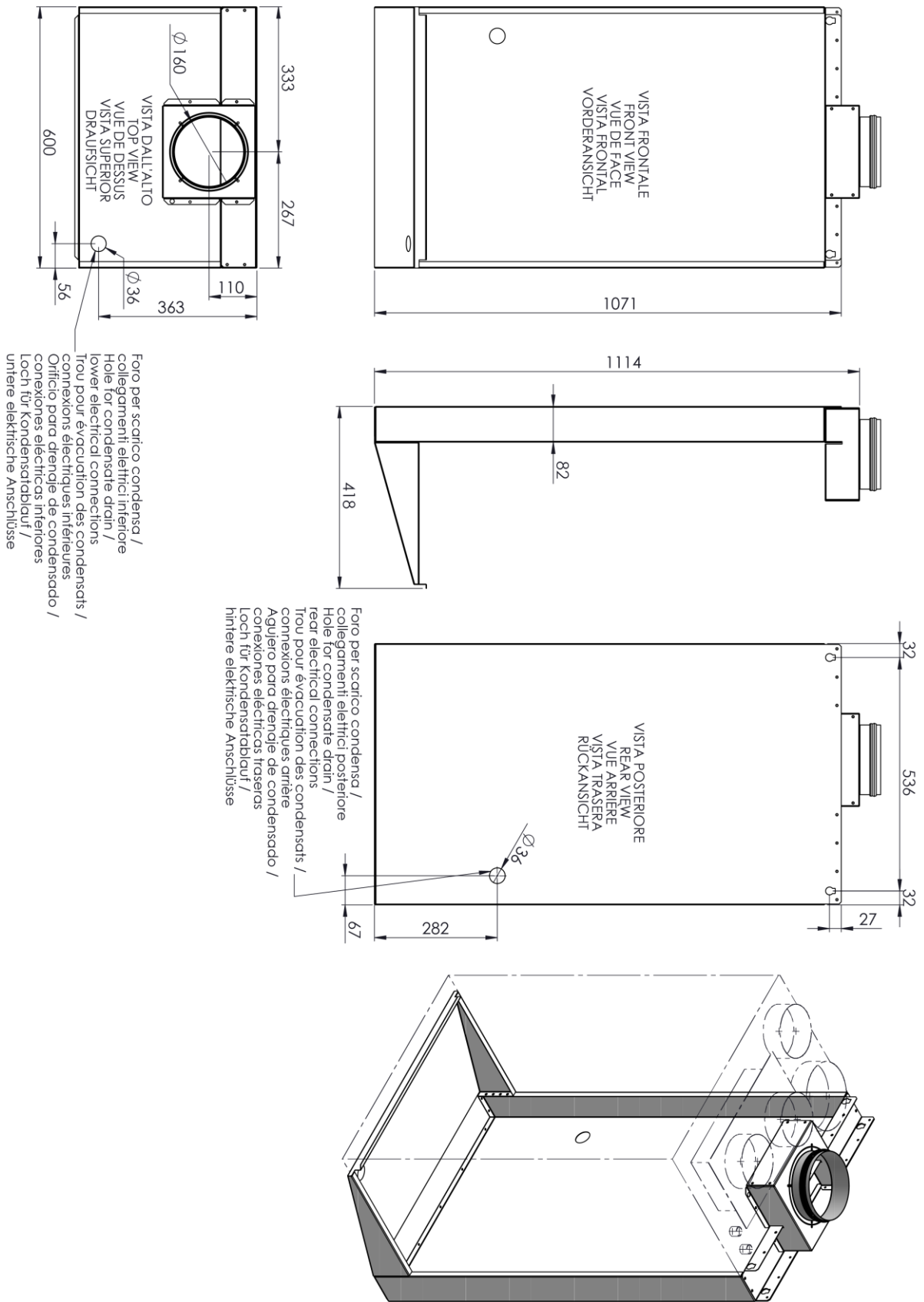

## 1.7 D-DRY REC-VE 035

### 1.7.1 Dimensionale D-DRY REC-VE 035 (tutte le versioni)

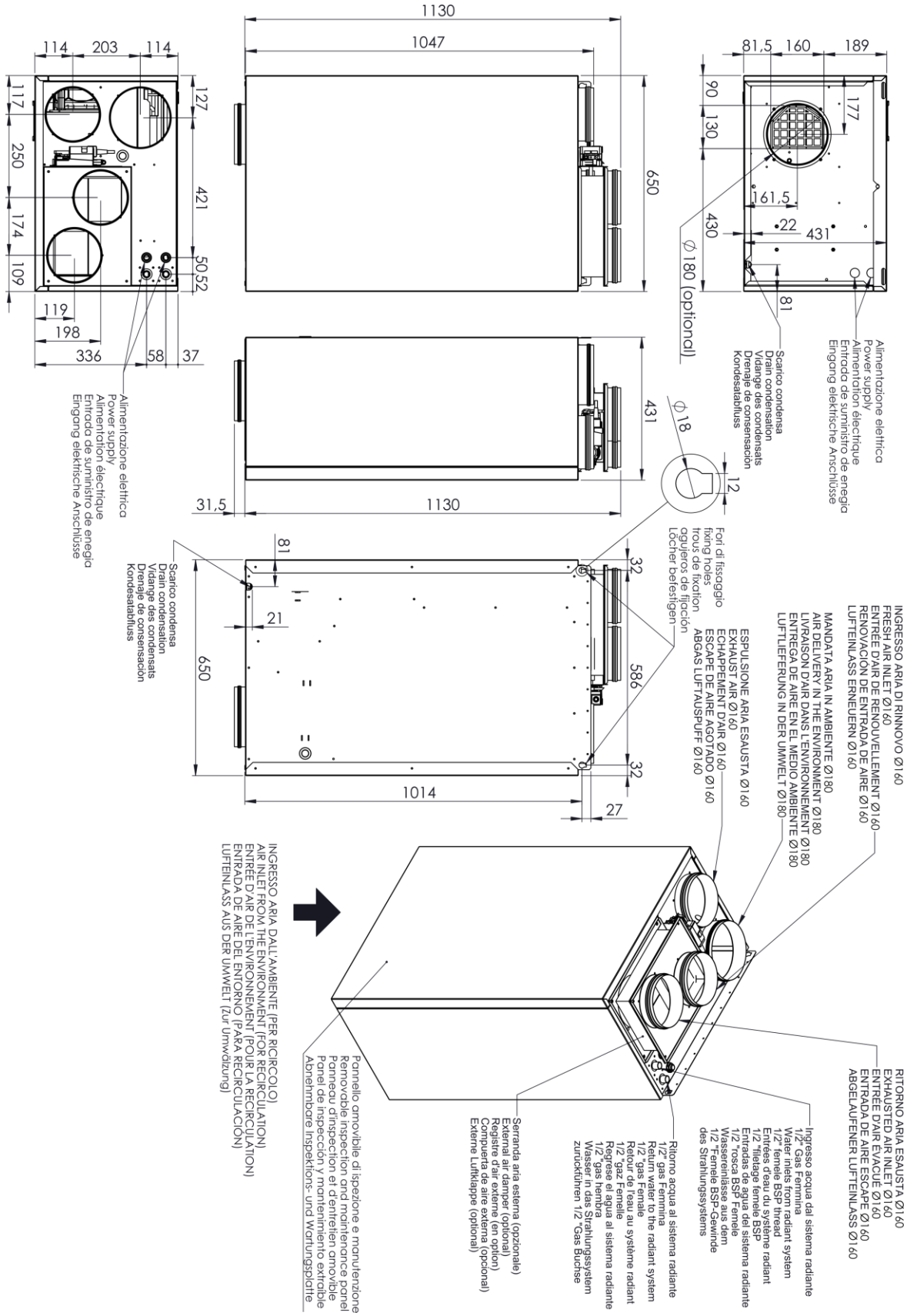



1.7.2 Dimensionale plenum ricircolo D-DRY REC-VE 035

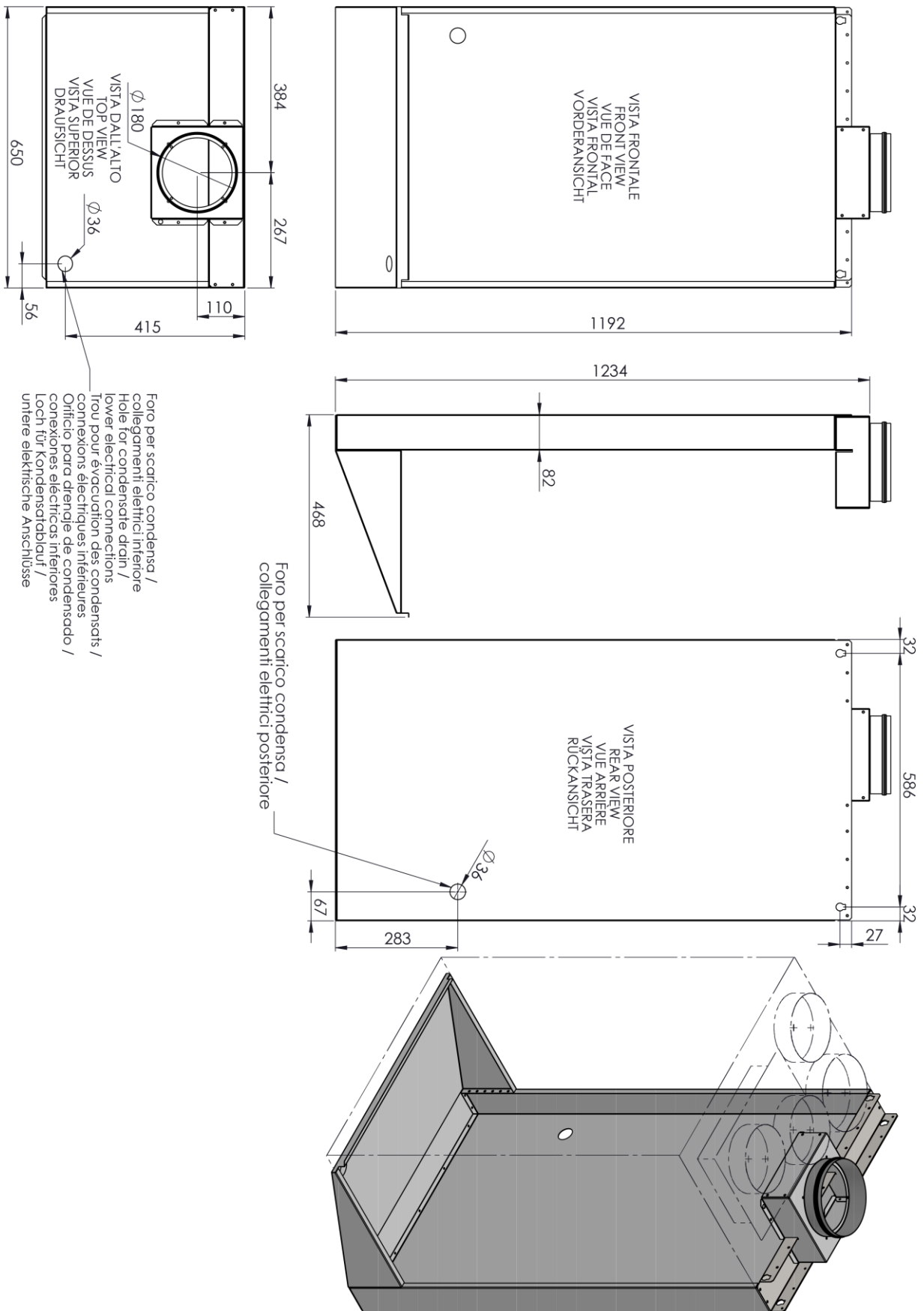

## 1.8 D-DRY REC-VE 050

### 1.8.1 Dimensionale D-DRY REC-VE 050 (tutte le versioni)

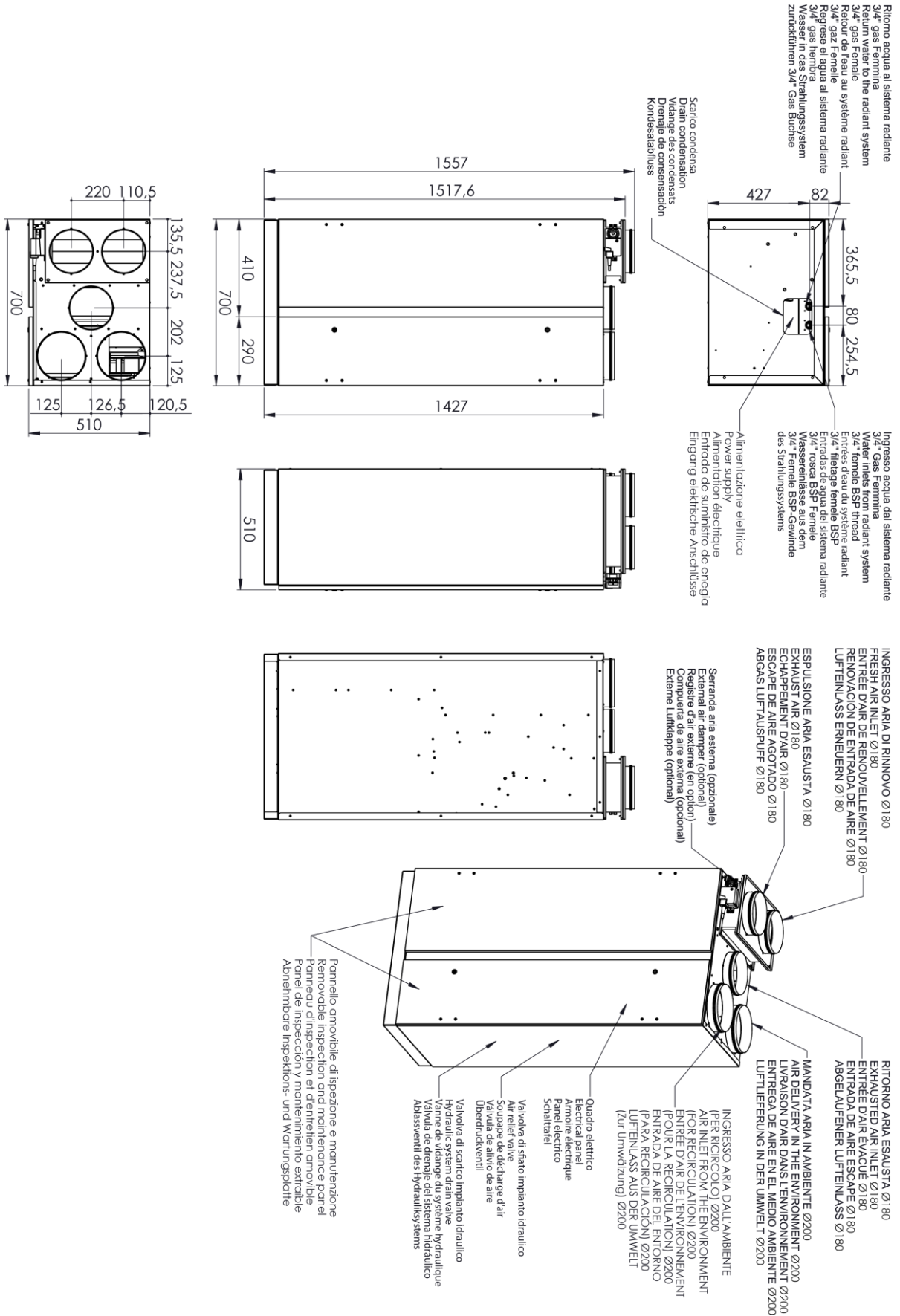



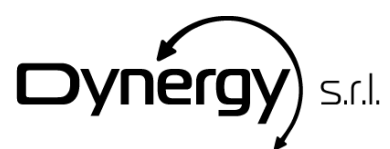

Via Terezin, 9 · 42122 Reggio Emilia  
dynergy@dynergysrl.it · www.dynergysrl.it  
Cod. Fisc. - Partita IVA 02354100352